

# **USER'S MANUAL**

**MODEL 8875**

**CABLE AND PIPE LOCATOR**



# TABLE OF CONTENTS

	PAGE
<b>SECTION 1 - GENERAL INFORMATION</b> .....	1
INTRODUCTION .....	1
PREPARE FOR USE .....	1
<b>SECTION 2 - TRANSMITTER OPERATION</b> .....	3
SELECT THE LOCATING METHOD .....	4
AC RESISTANCE INDICATIONS .....	5
8870 TRANSMITTER RECHARGEABLE BATTERY OPTION .....	5
RECHARGING THE BATTERY/EXTERNAL POWER PACK.....	6
AC CHARGER:.....	6
AUTOMOTIVE CHARGER/POWER PACK .....	6
POWER UTILITY CONNECTION .....	7
TELCO CIRCUIT CONNECTION.....	8
FLEXICOUPLER CONNECTION.....	9
INDUCTIVE CONNECTION.....	10
DIRECT CONNECTION .....	12
NOTES ON SELECTING THE TRACING SIGNAL .....	13
CONTINUOUSLY GROUNDED CIRCUIT .....	14
TELEPHONE DIRECT SHIELD CONNECTION.....	15
TELEPHONE DIRECT PAIR CONNECTION .....	16
<b>SECTION 3 - RECEIVER OPERATION</b> .....	17
LOCATING THE CABLE OR PIPE .....	18
SELECTING THE LOCATING MODE.....	18
PEAK MODE LOCATING.....	19
NULL MODE LOCATING .....	20
ABSOLUTE SIGNAL STRENGTH .....	21
SIGNAL STRENGTH ADJUSTED FOR DEPTH (CURRENT MEASUREMENT) .....	22
GAIN CHANGE INDICATION .....	23
PASSIVE 50/60HZ LOCATING .....	23
PUSH-BUTTON DIGITAL DEPTH .....	23
DEPTH MEASUREMENT 45° ANGLE METHOD.....	25
TILTED MAGNETIC FIELD IDENTIFICATION .....	26
<b>SECTION 4 - FAULT LOCATING WITH THE 8875</b> .....	27
INTRODUCTION .....	27
GROUND RETURN PROBE.....	28
<b>SPECIFICATIONS</b> .....	33
<b>FACTORY SERVICE</b> .....	35
<b>WARRANTY</b> .....	36

## LIST OF FIGURES

FIGURE	PAGE
1 TRANSMITTER CONTROLS AND INDICATORS.....	3
2 MULTIPLE GROUNDED CIRCUIT CONNECTION.....	7
3 MULTIPLE GROUND POWER UTILITY APPLICATION.....	7
4 MULTIPLE TELCO GROUND APPLICATION.....	8
5 FLEXICOUPLER CONNECTION.....	9
6 INDUCTIVE CONNECTION.....	10
7 INDUCTIVE CONNECTION 30° ANGLE.....	11
8 DIRECT CONNECTION.....	12
9 CONTINUOUSLY GROUNDED CIRCUIT.....	14
10 TELEPHONE DIRECT SHIELD CONNECTION.....	15
11 TELEPHONE DIRECT PAIR CONNECTION.....	16
12 RECEIVER CONTROLS AND INDICATORS.....	17
13 LOCATING THE CABLE OR PIPE.....	18
14 DETERMINE CABLE PATH IN PEAK MODE.....	19
15 DEPTH MEASUREMENTS 45° ANGLE METHOD.....	25
16 SIGNAL RETURN THROUGH AN INSULATION FAULT.....	27
17 COLLAPSIBLE GROUND RETURN PROBE.....	28
18 GROUND RETURN PROBE INSERTION.....	29
19 SPOKED WHEEL RETURN PATHS.....	29
20 GROUND RETURN PROBE FAULT LOCATING.....	30
21 GRP RECEIVER METER RESPONSE WITH DISTANCE.....	31
22 FAULTS BENEATH PAVED SURFACES.....	32

# SECTION 1-GENERAL INFORMATION

## INTRODUCTION

Congratulations on the purchase of your new Rycom Cable Locator. The Rycom 8875 locator is used to detect buried power cables, CATV cables, gas and water pipes, sewer lines, telephone cables, and fiber optic cables.

The transmitter applies a tracing signal onto a cable or pipe. The receiver detects the tracing signal. You can locate the path of a buried pipe or cable by following the tracing signal.

The 8875 Locator includes:

1. 8875 Receiver Unit..... 001 00107 01
2. 8875 Transmitter Unit..... 001 00108 01
3. Red/Black Test Cord ..... 151 00052 00
4. Rycom Ground Rod..... 211 00006 01
5. User's Manual..... 030 00052 00
6. Eight Duracell 1.5V D-size Batteries ..... 770 00023 00  
(For Non-Rechargeable Transmitter Only)
7. Six Duracell 1.5V C-size Batteries ..... 770 00022 00
8. Headset Stereo..... 743 00013 00
9. AC Battery Charger ..... 750 00004 00  
(For Rechargeable Transmitter Only)

## PREPARE FOR USE

Unpack your 8875 locator. Make sure there is no shipping damage, and all the parts are included.

Remove the receiver from the case. Locate the battery compartment. Install the six 1.5V Duracell C-size batteries as marked on the battery holder. Install the battery cover and tighten the retaining screw.

Remove the transmitter from the case. Locate the battery compartment on the bottom of the transmitter. Remove two screws from the battery compartment door. Install the eight Duracell D-size batteries as marked on the battery holder. Install the battery cover and tighten the two retaining screws. NOTE: For longer battery life and reliable operation under adverse conditions use only Duracell alkaline batteries.

**WARNING: LETHAL VOLTAGES PRESENT AT THE OUTPUT OF THE TRANSMITTER**

SECTION 2-TRANSMITTER OPERATION

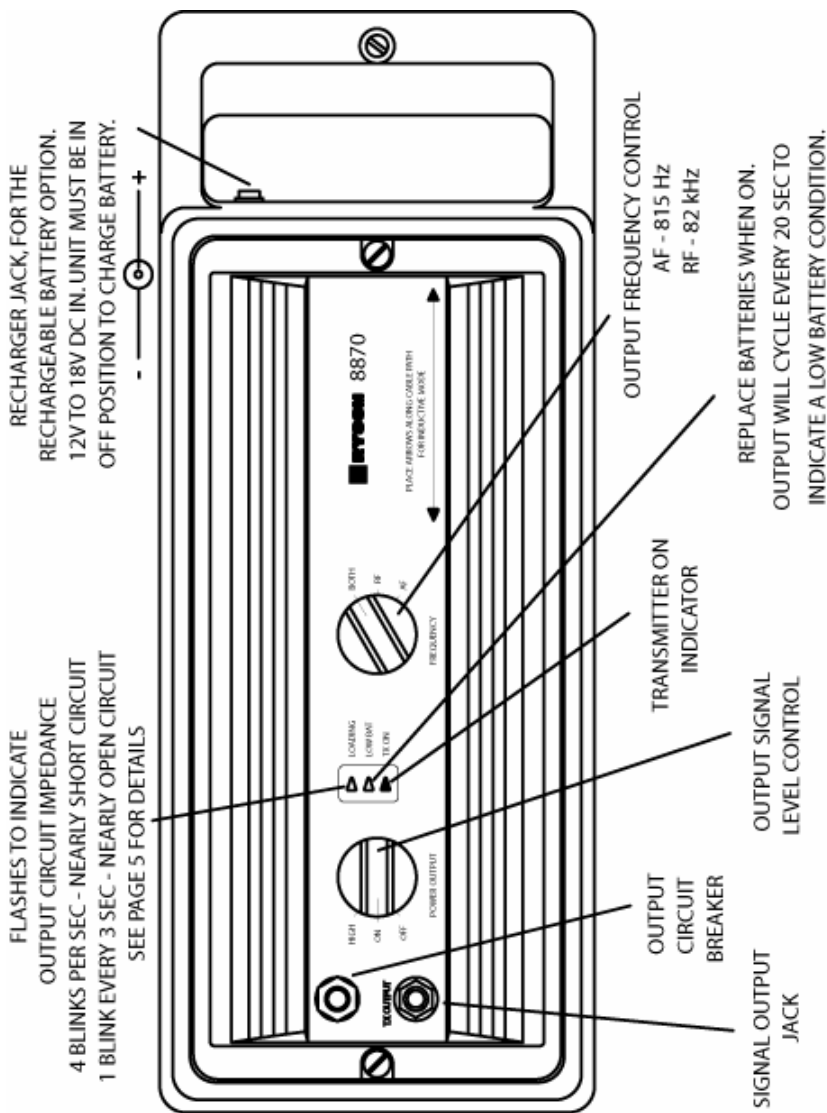

FIGURE 1 - TRANSMITTER CONTROLS AND INDICATORS

# SELECT THE LOCATING METHOD

Choose the heading below that matches your job, then pick the locating method. The first method listed under each heading will produce the best results with the simplest connection. Direct connection is always recommended. After selecting the locating method, turn to the page that tells how to connect the equipment. For the most reliable locate, it is recommended to use low power and low frequency(AF) when possible. Refer to page 34 for output power information.

<b>ELECTRICAL CABLE AND CABLE TV (CATV)</b>	<b>PAGE</b>
Multiple Grounded Circuit .....	7
Flexicoupler .....	9
Inductive Connection .....	10
Direct Connection .....	12
60 Hz Passive Locating .....	23
<b>GAS AND WATER PIPE</b>	
Continuously Grounded Circuit.....	14
Flexicoupler .....	9
60 Hz Passive Locating .....	23
<b>TELEPHONE CABLE</b>	
Multiple Grounded Circuit .....	7
Telephone Direct Shield Connection.....	15
Telephone Direct Pair Connection.....	16
60 Hz Passive Locating .....	23
<b>FIBER OPTIC CABLES</b>	
Multiple Grounded Telco Circuit .....	8
Inductive Connection .....	10
Telephone Direct Shield Connection.....	15
60 Hz Passive Locating .....	23

NOTE: The output will cycle when the LOW BAT indicator is activated to inform the user a LOW BAT condition is present

The inductive connection method requires using the 82 kHz (RF) high frequency setting.

# AC RESISTANCE INDICATIONS

NO. OF BLINKS	IMPEDANCE $\Omega$
4 BLINKS PER SEC	5 $\Omega$ - 15 $\Omega$ CIRCUIT
2 BLINKS PER SEC	15 $\Omega$ - 100 $\Omega$ CIRCUIT
1 BLINK PER SEC	100 $\Omega$ - 400 $\Omega$ CIRCUIT
1 BLINK EVERY 2 SEC	400 $\Omega$ - 1800 $\Omega$ CIRCUIT
1 BLINK EVERY 3 SEC	1800 $\Omega$ - OPEN CIRCUIT

**NOTE:** WHEN THE LOAD INDICATOR DOES NOT BLINK IN THE AF MODE, THIS INDICATES THE RED/BLACK CORD NEEDS TO BE PLUGGED IN.

## 8870 TRANSMITTER RECHARGEABLE BATTERY OPTION

If your 8870 transmitter has a rechargeable battery, the battery cover will extend past the main transmitter housing shell approximately 1/2". The charger plug is located near the inner wall of the carrying handle on the transmitter housing. The rechargeable battery is a 12V 7 Amp Hr sealed lead-acid, Rycom # 770 00019 00. The battery may be replaced by removing the back cover and four nuts on each side of the battery bracket. Once the bracket is removed, the two red/black wires can be disconnected from the battery terminals by pulling the 1/4" spade connectors off.

An automatic shut down circuit protects the lead acid battery from excessive discharge. This circuit trips an internal shutoff system that activates when the battery voltage discharges down to 8.2V. The auto shutoff circuit can be reset by turning the power switch off. The LOW BAT icon located on the LCD display turns on when the battery discharges down to 10.5V. The time between a LOW BAT indication and an auto shutoff, will vary from 30 minutes to 15 minutes depending on the charge level of the battery, when the LOW BAT condition occurs. Also, when the LOW BAT icon is activated, the output will cycle every 20 seconds to inform the user a LOW BAT condition is present.

## **RECHARGING THE BATTERY/EXTERNAL POWER PACK**

### **AC CHARGER:**

A discharged battery can be fully charged in 24 hours or less with the Rycom AC charger # 750 00004 00. Avoid over charging, this will shorten battery life. A partially discharged battery should be charged for a shorter time. When charging the battery with the AC charger, the transmitter power switch must be in the OFF position. Do not attempt to power the transmitter with the AC charger. Possible damage could result to the charger if the switch is on when attempting to charge the battery with the AC charger.

### **AUTOMOTIVE CHARGER/POWER PACK**

A discharged battery can be fully charged in 5 hours or less with the Rycom Automotive charger # 750 00006 01. Typically, every 10 minutes of charge time will give about 20 minutes of battery usage. When charging the battery with the Automotive charger, the transmitter power switch must be in the OFF position. It is possible to power the transmitter from the Automotive charger, however, when the transmitter is turned on with the charger plugged in, the battery can not be charged simultaneously.

# POWER UTILITY CONNECTION

**NOTE:** The transmitter should be turned off when connecting or disconnecting the Red/Black leads.

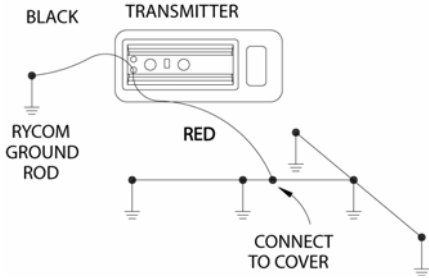

**FIGURE 2 – MULTIPLE GROUNDED CIRCUIT CONNECTION**

This method uses the existing ground points that are already exposed and available to you. It is not necessary to disconnect the service. The range of operation is up to one-half mile.

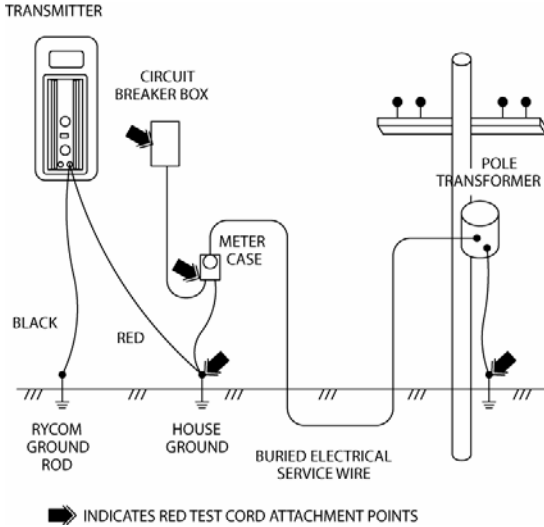

**FIGURE 3 – MULTIPLE GROUND POWER UTILITY APPLICATION**

# TELCO CIRCUIT CONNECTION

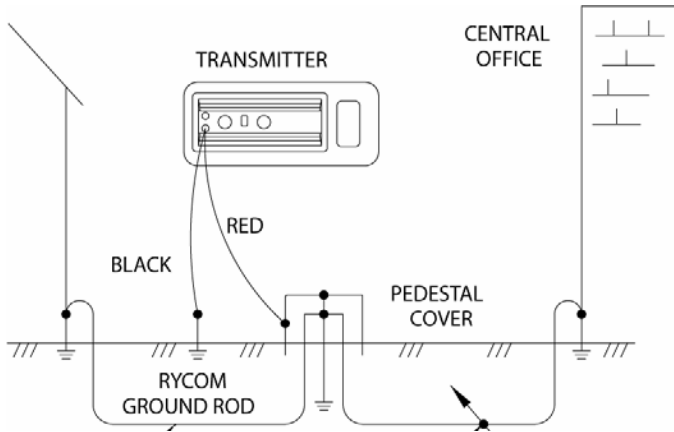

FIGURE 2 - MULTIPLE GROUND TELCO APPLICATION

Connect the Red Test Cord to an existing ground point. Place the Rycom Ground Rod approximately 10 feet from this point, at an angle of 90 degrees to the buried cable or pipe. Push the Rycom Ground Rod into the ground eight to ten inches. Connect the Black Test Cord to the Rycom Ground Rod.

Plug the Red/Black Test Cord into the TX OUTPUT jack. Set the FREQUENCY switch to the AF position. The TX ON indicator will start blinking.

Turn to page 17 to begin locating the cable or pipe.

# FLEXICOUPLER CONNECTION

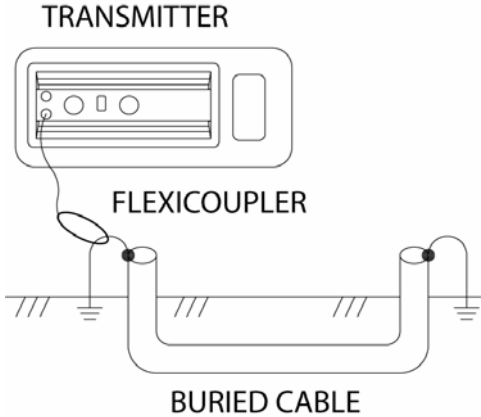

**FIGURE 3 - FLEXICOUPLER CONNECTION**

The optional Flexicoupler is very easy to use, and services do not have to be interrupted. The operation range is shorter than for direct connection methods. The tracing signal can be affected by neighboring cables and pipes. You do not need the Red/Black Test Cord or the Rycom Ground Rod for this method.

Successful flexicoupler operation requires an insulated conductor that is grounded on both ends.

Loop the flexicoupler around the cable and connect the two ends. It is important to connect the flexicoupler around the cable you want to trace, as shown above. Connecting the flexicoupler around the ground wire that connects two cables, will result in a weaker signal. The range will be shorter, and you may have trouble telling one cable from another.

Plug the Flexicoupler Test Cord into the TX OUTPUT jack. Set the FREQUENCY switch to the RF position. The LOADING indicator will start blinking.

Turn to page 17 to begin locating the pipe or cable.

**NOTE:** Set the switch on the flexicoupler test cord plug to the desired locate frequency (either AF or RF). Then set the transmitter FREQUENCY switch to the AF or RF position (same as flexicoupler).

# INDUCTIVE CONNECTION

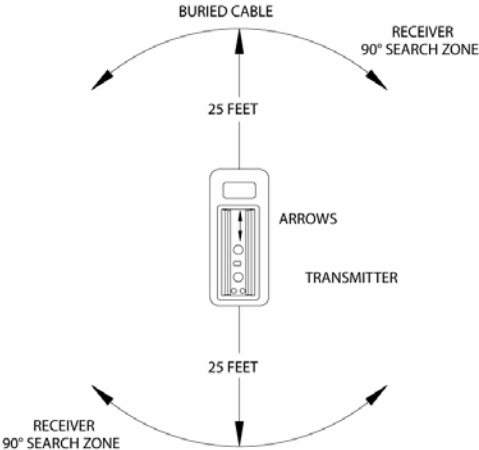

**FIGURE 4 - INDUCTIVE CONNECTION**

This method is convenient to use, and services are not interrupted. No test cords or connections are needed. The cable or pipe must have good insulation or non-conductive coating, or the operating range will be very short.

Place the transmitter on the ground, as close as possible to the path of the cable or pipe. Align the ARROWS on the Transmitter Control Panel at a moderate angle to the cable or pipe. Set the FREQUENCY switch to the RF position. Turn the Transmitter on; the LOADING indicator will start blinking. First locate the broad transmitter null, then move toward the expected cable path while looking for the signal carried by the cable.

Start tracing the path with the receiver 25 feet from the transmitter. Search in the 90 degree zone as shown above. Locate the cable or pipe, and follow the path. If the signal becomes weak, move the Transmitter to a point 25 feet behind the last strong signal, and continue searching.

The transmitter will produce its own transmitter null when the receiver is within 25 feet of the 8870 transmitter. If the locating situation requires that you locate near the transmitter null, place the transmitter at a 30° angle over the target conductor. (See Figure 7). In this example, two nulls will be present, one transmitter null and one cable/conductor null.

Turn to page 17 to begin locating the cable or pipe.

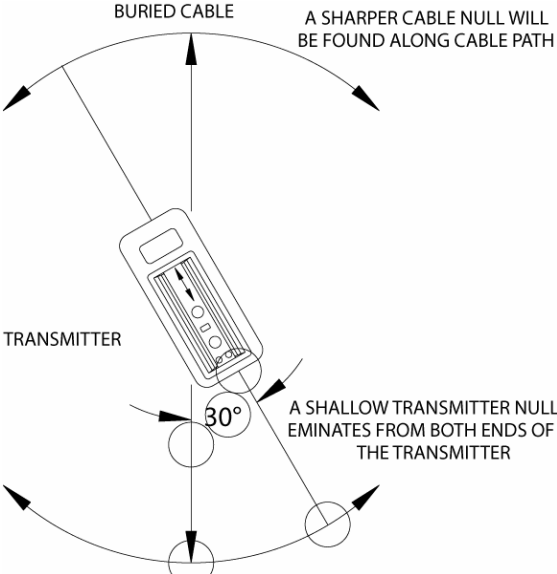

**FIGURE 5 - INDUCTIVE CONNECTION 30° ANGLE**

# DIRECT CONNECTION

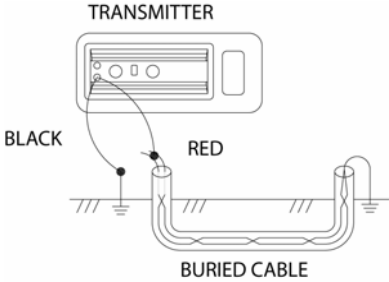

**FIGURE 6 - DIRECT CONNECTION**

This method is reliable and free of interference. The Rycom Ground Rod is not needed. The range of operation is up to 15 miles. Utility services must be interrupted. This method is restricted to qualified employees and service technicians.

Disconnect the cable shield or neutral wire. Connect the Red Test Cord to the cable shield or neutral wire. Connect the Black Test Cord to the system ground, where the cable shield or neutral wire was previously connected.

**NOTE:** The locating method shown above requires system interruption and should only be performed by service technicians with authorized access to these utilities.

Plug the Red/Black Test Cord into the TX OUTPUT jack. Set the FREQUENCY switch to the AF position. Turn the unit on. The LOADING indicator light will start blinking.

## NOTES ON SELECTING THE TRACING SIGNAL

The choice of AF or RF frequency is dependant on the conditions of the locate.

The AF and RF signals each have their advantages. Use RF and AF in combination for the highest confidence in locating the path. Begin by using the AF signal, and continue as long as you are confident in the results. If the signal suddenly becomes very weak, disappears, or takes an unexpected turn, change to the RF signal to verify your results.

The AF signal is usually preferred to the RF signal, because it is much less susceptible to locating errors caused by nearby cables or pipes. The AF locating range is much longer than for the RF signal. The AF signal will not travel well through disconnected shield bonds or insulated pipe bushings. You may have to inspect and correct these problems as you go.

The RF feature is sometimes better than the AF frequency for locating sharp corners in cables or pipes. The RF signal is also better for "jumping" disconnected shield bonds or grounds, or operating near concrete reinforcing bar. Sudden changes in the tracing signal may indicate one of these characteristics. The locating range is quite short for this signal, however, so the transmitter must be repositioned more often during the tracing operation. This frequency is also useful for applying a signal using Rycom's Flexicoupler (see figure 5).

Turn to page 17 to begin locating the cable or pipe.

# CONTINUOUSLY GROUNDED CIRCUIT

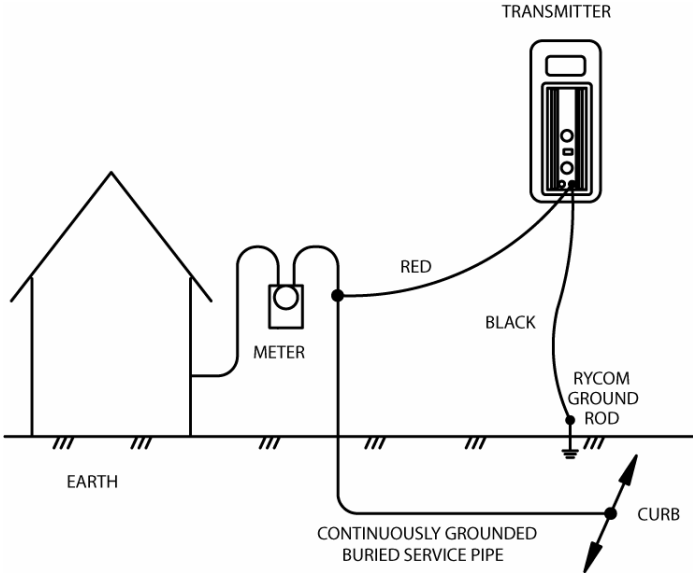

**FIGURE 7 - CONTINUOUSLY GROUNDED CIRCUIT**

The locating range for bare uninsulated pipe is typically 300 feet and may require frequent relocation of the Transmitter. If the locating range seems very short or unreliable, there may be an insulating bushing in the buried pipe. Try to bypass the insulated fitting by using a different connection point.

Connect the Red Test Cord to the shutoff valve wrench surface or union fittings near the gas or water meter. Place the Rycom Ground Rod approximately 10 feet from this point, at an angle of approximately 90° to the buried cable or pipe. Press the Rycom Ground Rod eight to ten inches into the ground. Connect the Black Test Cord to the Rycom Ground Rod.

Plug the Red/Black Test Cord into the TX OUTPUT jack. Set the FREQUENCY switch to the AF position. The LOADING indicator light will start blinking after the transmitter is turned on.

Turn to page 17 to begin locating the cable or pipe.

## TELEPHONE DIRECT SHIELD CONNECTION

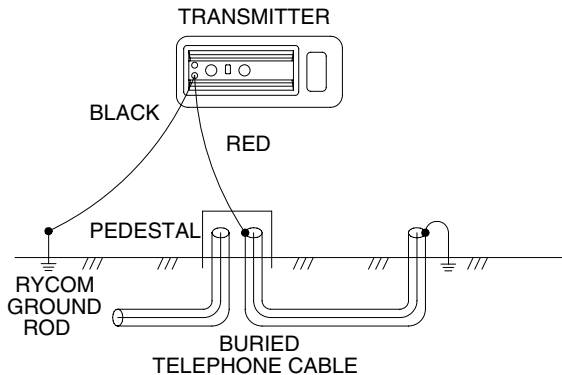

**FIGURE 8 - TELEPHONE DIRECT SHIELD CONNECTION**

This method is preferred for telephone service, because there is usually a ground lug available for making connections. Damage to the cable is unlikely. It provides good reliability and service is not interrupted. A telephone company employee or contract locator is required to make the connections. Readings may be confusing if several cable shields are bonded together.

Disconnect the shield from the system ground. Connect the Red Test Cord to the cable shield. Connect the Black Test Cord to the Telephone pedestal or previous shield attachment point.

Plug the Red/Black Test Cord into the TX OUTPUT jack. Set the FREQUENCY switch to the AF position. The LOADING indicator will start blinking when the transmitter is turned on.

Turn to page 17 to begin locating the cable or pipe.

## TELEPHONE DIRECT PAIR CONNECTION TRANSMITTER

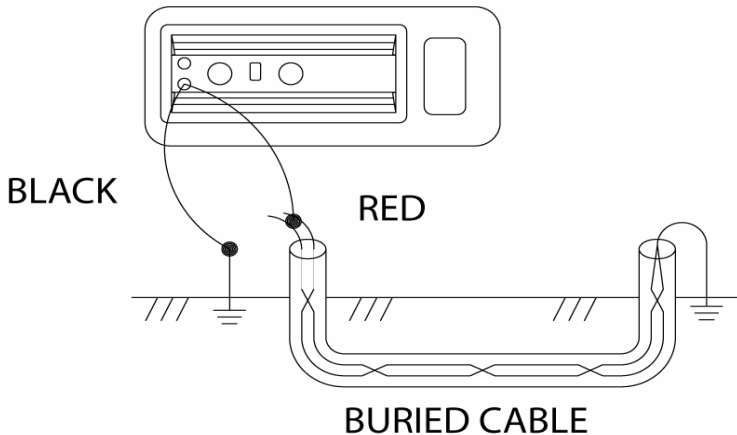

**FIGURE 9 - TELEPHONE DIRECT PAIR CONNECTION**

**NOTE:** This method will not work with a floating ground ESS #5 office.

This method provides a very high quality path to the central office. It requires a telephone company employee or authorized contract locator to make the connections. Service is interrupted during the tracing operation. Locating errors due to the signal going the other direction or coupling into other cables are unlikely.

Select one of the wire pairs in the cable you want to trace. Connect the Red Test Cord to the tip side of the pair and locate toward the central office. Do not use insulation piercing clips.

Connect the Black Test Cord to the system ground at any convenient point.

Plug the Red/Black Test Cord into the TX OUTPUT. Set the FREQUENCY switch to the AF position. The LOADING indicator will start blinking when the transmitter is turned on.

Turn to page 17 to begin locating the cable or pipe.

# SECTION 3 - RECEIVER OPERATION

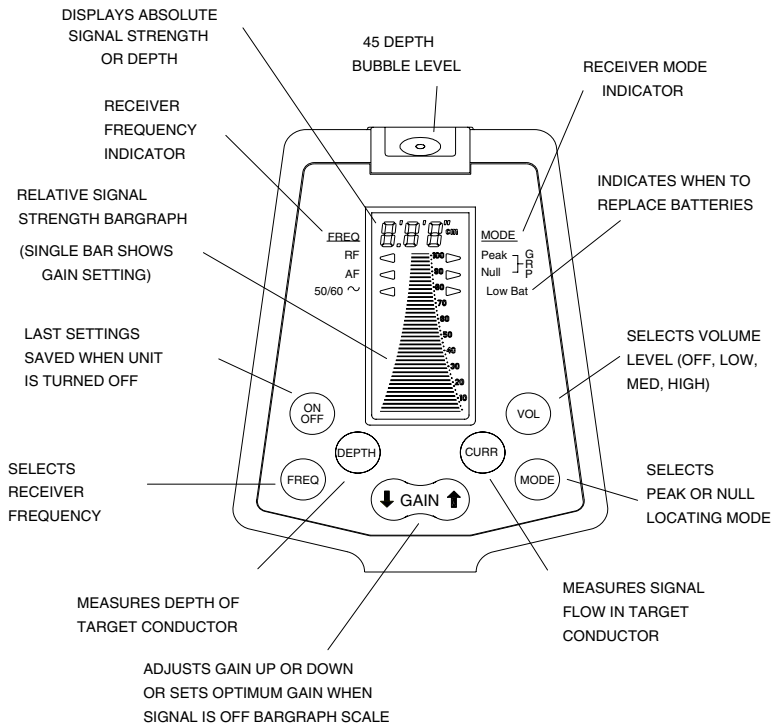

**FIGURE 10 - RECEIVER CONTROLS AND INDICATORS**

# LOCATING THE CABLE OR PIPE

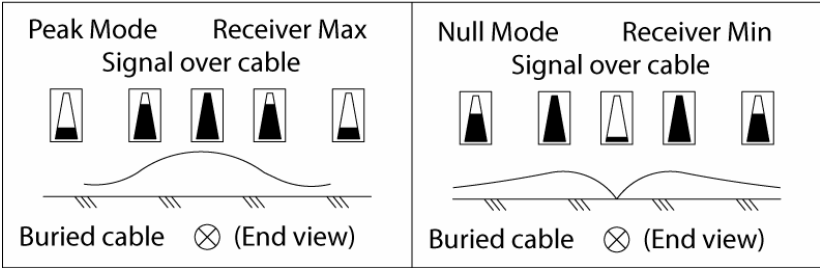

**FIGURE 11 - LOCATING THE CABLE OR PIPE**

Make sure the Transmitter is connected and turned on. Move about 15 feet away from the Transmitter, along the path. (Move about 25 feet for the INDUCTIVE search method).

Hold the receiver so that you can see the LCD bargraph and controls easily. Make sure the receiver and transmitter FREQUENCY are both set for the same frequency (either AF or RF).

## SELECTING THE LOCATING MODE

Press the MODE button to select the desired peak or null locating method

## PEAK MODE LOCATING

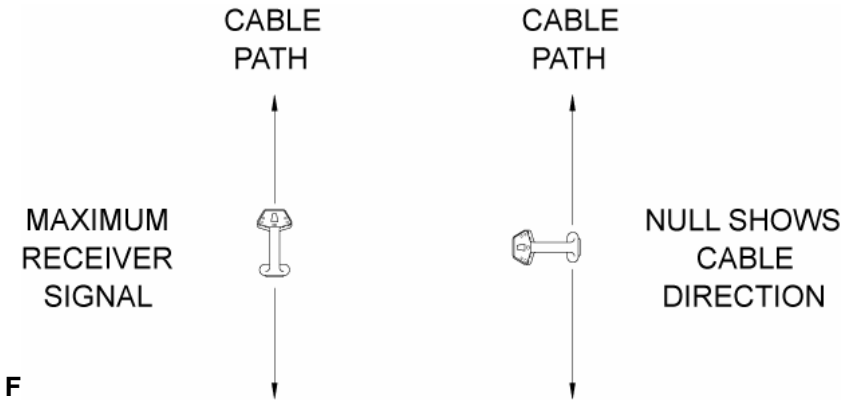

Keep the 8875 Receiver approximately vertical. Swing the receiver across the path. When the receiver is directly above the cable or pipe, rotate the Receiver for a maximum signal (see figure 13). As you swing the receiver away from the cable path the meter reading (and audio frequency response) will drop off. If you rotate the receiver while over the cable, a sharp null will identify the cable direction. It is aligned with the flat side of the receiver.

Trace the path by walking away from the transmitter at a moderate pace. Swing the receiver left and right as you walk, following the Peak indications.

As you trace the path, the Peak meter reading may slowly fade as you move away from the transmitter. Press and release the gain buttons as needed to compensate for changes in Peak signal level. If the Peak meter reading suddenly changes in level (higher or lower), you may have found one of the following:

- a. a junction where the signal divides and goes several directions.
- b. a break in the cable or shield.
- c. a change in depth of the cable or pipe.
- d. an insulated pipe fitting.
- e. a slack loop of cable.

If you can no longer trace the path, even with the gain set to maximum, connect the transmitter to the far end of the path and trace back to the point you lost the signal.

Mark the straight section of the path every few feet. Mark sharp curves, loops, and cable bundles every few inches. Sharp changes in the path cause the receiver Peak and Null indications to behave differently than when tracing a straight path. Practice on the path that you know has turns and laterals in it, so you will recognize these conditions in the field.

## **NULL MODE LOCATING**

Swing the receiver across the cable path. When the receiver is directly above the cable or pipe, a Null (lowest meter reading, and lowest audio tone) will occur. When you swing the receiver to the left or right of the Null point, the meter reading will rise to a maximum point (Peak), and the audio tone will be at its highest pitch. When the receiver is swung beyond the peak, the meter reading will begin to fade.

Trace the path by walking away from the transmitter at a moderate pace. Swing the receiver left and right as you walk, following the Null indications.

As you trace the path, the Peak meter readings may slowly fade as you move away from the transmitter. Press and release the GAIN buttons as needed to compensate for changes in signal level. If the Peak meter readings suddenly changes in level (higher or lower), you may have found:

- a. a junction where the signal divides and goes several directions.
- b. a break in the cable or shield.
- c. a change in depth of the cable or pipe.
- d. an insulated pipe fitting.
- e. a slack loop of cable.

If you can no longer trace the path, even with the GAIN control set to maximum, connect the Transmitter to the far end of the path, and trace back.

Mark the straight sections of the path every few feet. Mark sharp curves, loops, and cable bundles every few inches.

Sharp changes in the path cause the receiver indications to behave

differently than when tracing a straight path. Practice on a path that you know has turns and laterals in it, so that you will recognize them.

## **ABSOLUTE SIGNAL STRENGTH**

The Rycom 8875 Receiver provides the operator with a direct measurement of the received signal strength. This measurement is displayed with three numerical digits located at the top of the LCD display. The measurement range is from 0 to 999 indicating a very weak signal to very strong signal respectively. Absolute Signal Strength is independent of the GAIN setting or meter reading and gives the operator information about the actual amount of signal being radiated from the conductor and received by the 8875 Receiver.

Measuring Absolute Signal Strength at any time is done by reading the number at the top of the LCD display. The Absolute Signal Strength will not be displayed if the meter reading is too high or too low. Adjust the GAIN to move the meter reading to mid-scale. The numerical display will change from ' - - ' to a valid measurement.

Absolute Signal Strength measurements are more sensitive to signal changes than the meter display. Peaks and Nulls can be more precisely pin-pointed. This measurement can also be used to monitor signal loss as the conductor is being traced.

**NOTE:** It is important that the operator does not confuse Absolute Signal Strength with Signal Strength Adjusted for Depth (Current Measurement). Absolute Signal Strength only gives the operator a measurement of how much signal is being received from the conductor. If the depth of the conductor starts to increase, the Absolute Signal Strength measurement will decrease. This is because the distance between the signal source (the conductor) and receiver is increasing. In comparison, Signal Strength Adjusted for Depth takes the depth of the conductor into consideration. As the depth of the conductor changes, Signal Strength Adjusted for Depth measurements will remain the same. Signal Strength Adjusted for Depth is actually giving the operator an indication of the amount of signal flow, or current, through the conductor.

## **SIGNAL STRENGTH ADJUSTED FOR DEPTH (CURRENT MEASUREMENT)**

The Rycom 8875 Receiver contains a feature that is very useful in identifying a desired cable in a field of various conductors and/or utilities. It is not unusual for the target conductor (the conductor that is connected to the transmitter) to induce a signal into near by conductors in a crowded field. In these instances, the radiated signal on conductors close to the surface of the earth, may be stronger than the transmitter signal on the target conductor buried deep in the ground. The operator will find two or more paths and must determine which is the target conductor. By using the current measurement feature of the 8875 Receiver, the operator can determine the amount of AF or RF current flowing on the conductors, regardless of depth. The highest current flow indicates the target conductor.

Begin this measurement by locating the path of the cable(s) to be compared. Mark these locations as accurately as possible (See the sections on PEAK MODE LOCATING and NULL MODE LOCATING). Place the receiver vertical over one of the conductor marks and rest the foot of the locator on the ground. Holding the receiver vertical, press and release the CURR button. When the meter changes from a "thermometer" type display to a "bar" type display, hold the receiver still until the measurement stabilizes. The blinking bar indicates the signal level on the cable [adjusted for depth]. Next, move to the second cable and repeat the measurement. Again, the blinking bar will show the signal level on the conductor. In addition, the previous reading is shown as a solid bar. The higher of these two readings will show which conductor is carrying the most locating signal.

**NOTE:** The 8875 is designed to alert the operator of potential current measurement errors. If the display reads '**Err**' during a current measurement the receiver has detected a condition that could produce inaccurate readings.

Errors can exist when conductor signal flow is too small. Check transmitter hookup and far end access point for poor connections. This cause of error can be identified by a high gain setting (80 or greater on the bargraph display).

The receiver may also be detecting adjacent cables or is not directly over the target conductor. Verify target conductor path precisely before measuring current again.

If at anytime the display reads 'CAL', contact the factory for further information.

## **GAIN CHANGE INDICATION**

The GAIN Up and Down buttons are used to increase and decrease the gain in small amounts. If the meter reading is very low, pressing the GAIN Up button will center the meter reading to mid-scale. Likewise, if the meter reading is very high, pressing the GAIN Down button will center the meter reading to mid-scale.

## **PASSIVE 50/60HZ LOCATING**

The Rycom 8875 Receiver is capable of locating power utility frequencies. This mode is useful for locating underground primary and secondary power utilities. In certain circumstances, this mode will also locate water pipes, sewer lines, cable television, and telephone. The reason is that common electrical grounds are sometimes found among these various utilities.

Select the 50/60~ (Hz) frequency on the Receiver. Select Peak MODE. Locate the conductor similar to the Peak MODE instructions located on page 19 in this USER'S MANUAL.

This method is useful because of its speed and convenience. Start at a known reference point and keep in mind that other conductors in the area may produce this same locating signal.

The 8870 Transmitter is not required to locate in this mode.

## **PUSH-BUTTON DIGITAL DEPTH**

The Rycom 8875 Receiver can measure depth with the push of a button. The depth is displayed at the top of the LCD in feet and inches or meters and centimeters (factory selected). Push-button depth is useful in quickly determining the depth of the conductor during path locating.

Begin this measurement by locating the path of the cable. Move to the spot where you want to measure depth. Stay at least 15 feet away from the Transmitter. Pin-Point this location as accurately as possible (See the sections on PEAK MODE LOCATING, NULL MODE LOCATING and ABSOLUTE SIGNAL STRENGTH). Place the receiver vertical over the conductor and rest the foot of the locator on the ground. Holding the receiver vertical, press and release the DEPTH button. The receiver will briefly indicate a depth

measurement is being performed and then display the depth at the top of the LCD display.

Caution must be exercised when using the Push-Button Depth feature, as tilted magnetic fields and adjacent conductors can significantly influence this measurement. The operator should periodically check for adjacent conductors and tilted magnetic fields when taking Push-Button Depth readings. For information on identifying tilted magnetic fields refer to sections TILTED MAGNETIC FIELD IDENTIFICATION and DEPTH MEASUREMENT 45° METHOD.

**NOTE:** The 8875 is designed to alert the operator of potential depth measurement errors. If the display reads '**Err**' during a depth measurement the receiver has detected a condition that could produce inaccurate readings.

Errors can exist when conductor signal flow is too small. Check transmitter hookup and far end access point for poor connections. This cause of error can be identified by a high gain setting (80 or greater on the bargraph display).

The receiver may also be detecting adjacent cables or is not directly over the target conductor. Verify target conductor path precisely before measuring depth again.

If at anytime the display reads '**CAL**', contact the factory for further information.

# DEPTH MEASUREMENT 45° ANGLE METHOD

Bubble level centered

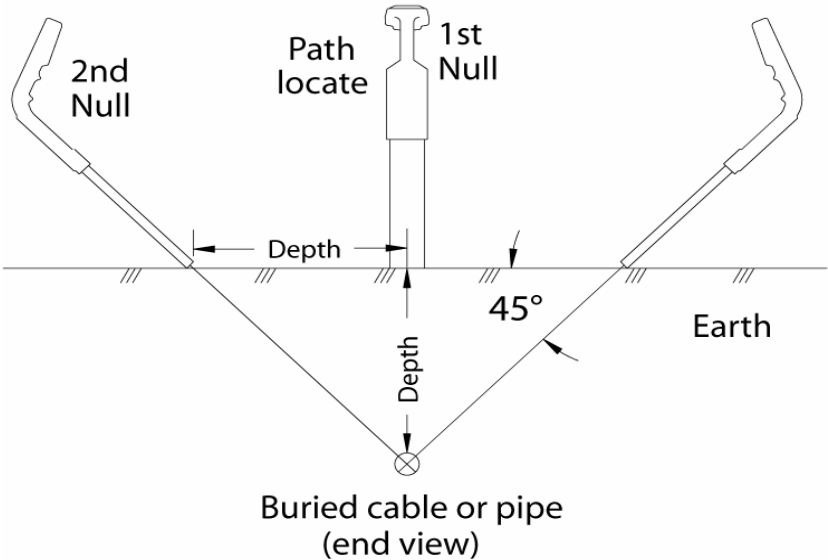

**FIGURE 13 - DEPTH MEASUREMENTS 45° ANGLE METHOD**

Move to the spot where you want to measure depth. Stay at least 15 feet away from the Transmitter. Swing the Receiver across the path until you locate the cable. Mark the path on the ground as precisely as possible using the null method.

Place the foot of the receiver on the ground with the meter facing up. Position the unit so that the bubble level on top of the meter is centered (45°). Pull the receiver away from the cable path (at 90° to the cable path) keeping the bubble level centered. When the locator indicates a null reading, mark the location of the locator's foot. The distance between the receiver and the cable path is the depth of the pipe or cable.

A false depth reading may be caused by near-by buried metallic objects, such as a second cable or pipe, sewer, fence, or railroad track. Confirm your depth measurement by repeating the above steps on the opposite side of the pipe or cable.

A difference of more than 5 inches in depth measurements indicates additional buried cables, pipes, or other objects may be present.

## **TILTED MAGNETIC FIELD IDENTIFICATION**

When adjacent cables or pipes are present in the right of way, they will sometimes create locating errors. Some of the transmitter signal is picked up by the adjacent conductors and reradiated so that it combines with the original signal. The result is a tilted magnetic field and the possibility of locating errors. This is also the reason that numeric depth readouts are sometimes in error.

You can verify the accuracy of path locating by doing a triangulation method depth locate on both sides of the cable path. (See the section on DEPTH MEASUREMENT 45° ANGLE METHOD). If the right side and the left side depth readings agree to within about 5 inches, your path locate is accurate. If the two depth readings do not agree, then dig with care. A closer locate would be halfway between the two outside depth locate marks.

This is an important technique that should be used to ensure the most accurate location possible. See Figure 15 DEPTH MEASUREMENTS 45° ANGLE METHOD for an illustration of this technique.

# SECTION 4 - FAULT LOCATING WITH THE 8875

## INTRODUCTION

Fault Locating determines the position of an insulation break on an underground conductor. In the case of an insulation fault, some of the signal will return to the Transmitter Ground Rod through a break in the insulation, as shown in Figure 16.

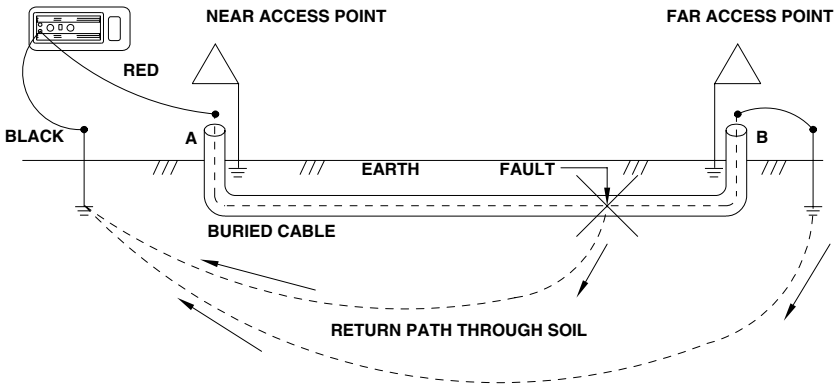

**FIGURE 14 - SIGNAL RETURN THROUGH AN INSULATION FAULT**

It is generally a good idea to locate the conductor path before attempting to fault locate. If, during the path locate, an *unusual* amount of signal loss occurs, one would suspect part of the signal has escaped to ground in the last several feet. Note: Signal would go to ground at a grounded splice point which would act as a fault during the path and fault locate.

Once the path is determined and there is a general area where a fault is expected, additional current can be forced to flow through the fault by disconnecting and isolating the far access point. If the current has no path to ground at the far access point it will be forced to seek ground at the fault. This will increase the current in the soil at the fault and the detectability of the fault.

# GROUND RETURN PROBE

To begin fault locating, open the ground return probe (GRP) and attach the 8875 receiver as shown. Plug the black molded cord into the Ground Return Probe handle with the straight connector. The GRP is collapsible for easy transport and storage (Figure17).

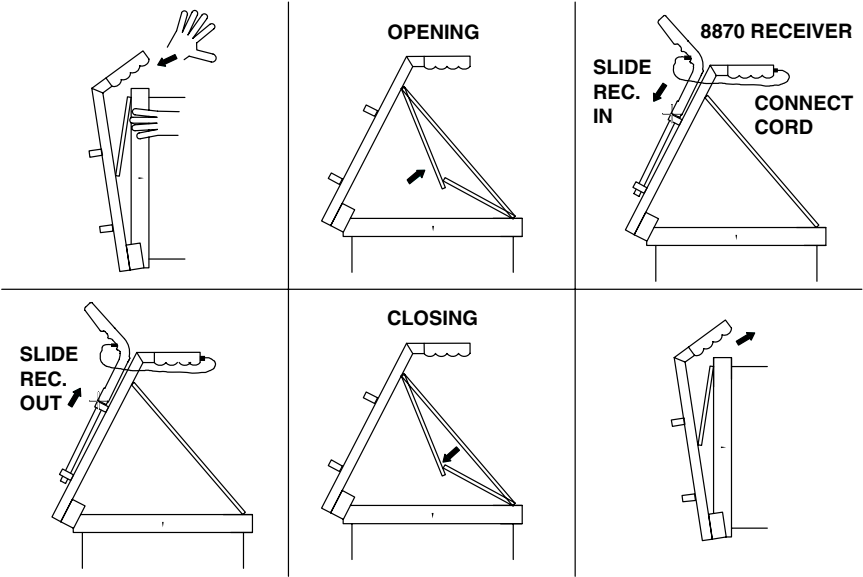

**FIGURE 15 - COLLAPSIBLE GROUND RETURN PROBE**

Circuitry between the two ground spikes provides a path for the current in the soil returning to the Transmitter Ground Rod. Current enters one spike of the GRP and exits the others. The GRP should be inserted into the soil with consistent force and depth (Figure 18).

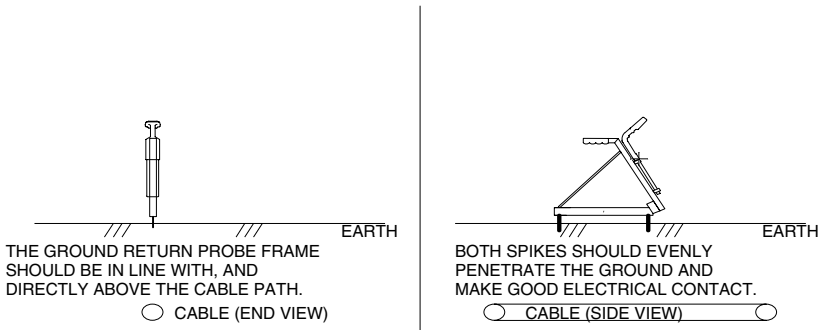

**FIGURE 16 - GROUND RETURN PROBE INSERTION**

The current in the soil spreads out from the fault like the spokes of a wheel. The current is highly concentrated in the soil near the fault as it begins its return, and near the Transmitter Ground Rod as it finishes its return. Notice that the current is widely dispersed in the soil between the fault and Transmitter Ground Rod in Figure 19.

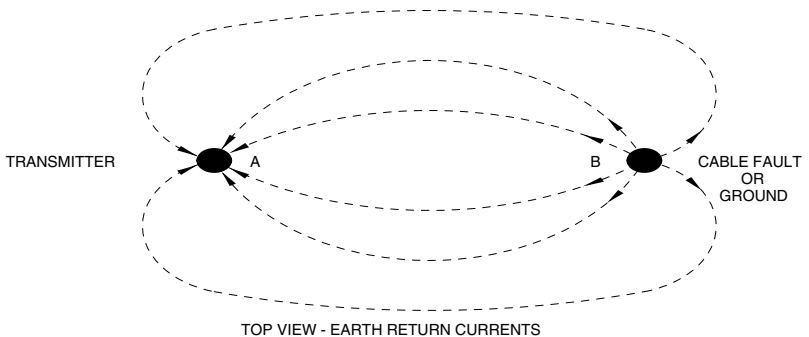

**FIGURE 17 - SPOKED WHEEL RETURN PATHS**

The 8875 Receiver measures the amount of current flowing through the GRP. As you walk the path using the GRP, drop the probe every three or four steps. As you near an area of high current concentration in the soil, the Transmitter Ground Rod or the Fault, the Receiver will record higher and higher readings. You will find it necessary to reduce the Receiver sensitivity by pressing the gain control button. Once the signal starts to increase, you should slow down, covering smaller segments of ground to avoid passing the fault.

The Receiver will continue to record higher current readings until one spike of the GRP passes the fault. When one spike of the GRP is on each side of the fault the currents subtract and produce a NULL. To record the deepest NULL, press the gain control button to keep the NULL on the meter scale and move the GRP an inch at a time until the deepest NULL is recorded. The fault lies in the center of the two GRP spikes (Figure 20).

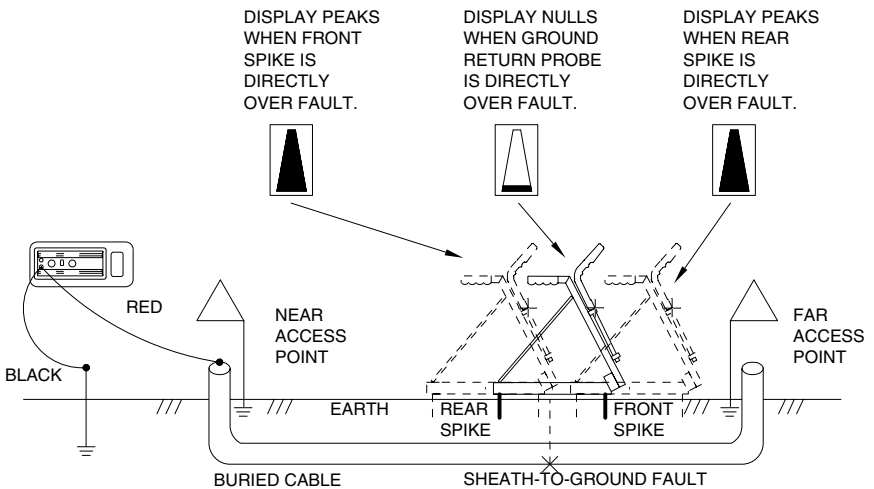

**FIGURE 18 - GROUND RETURN PROBE FAULT LOCATING**

In Figure 21 notice that there is a receiver signal level increase as the GRP approaches a fault and it moves away from the transmitter. A good cable will allow the locating signal to slowly decrease with distance from the transmitter. While this signature or signal pattern must be recognized, this method is usually more accurate than phase responding to/from types of instruments.

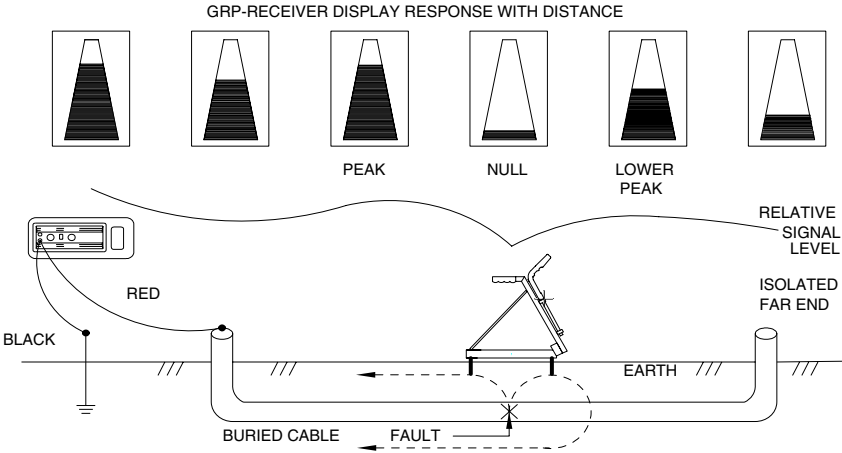

**FIGURE 19 - GRP-RECEIVER METER RESPONSE WITH DISTANCE**

A potential problem could exist if a fault should lie beneath a paved surface. In this case, the GRP will be used in the dirt at the side of the paved area. Since the return current in the soil begins its return from the fault - like the spokes of a wheel laying on the ground - equal amounts of current will enter the GRP if it is placed on the ground and positioned broadside to the fault. A NULL will be recorded when the exact broadside is accomplished. GRP adjustments can be made by slightly rotating the GRP to find the deepest NULL. The fault will lie on a straight line projected at a right angle from the center of the GRP. The operator should record this line over the paved area. Repeating this procedure from another locating near the paved area will produce another line. The intersection of the two lines is the location of the fault (Figure 22).

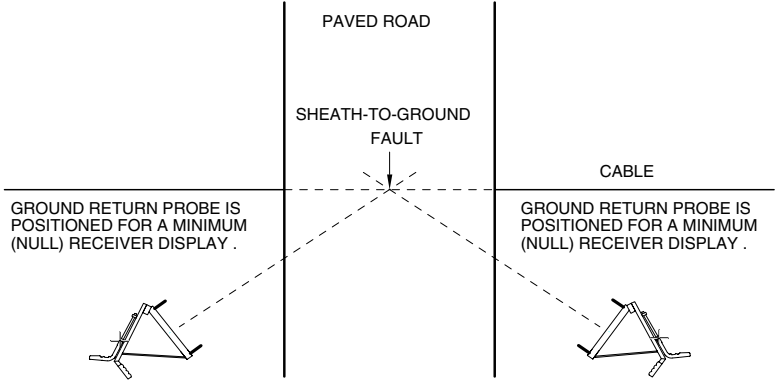

**FIGURE 20 - FAULTS BENEATH PAVED SURFACES**

# 8875 SPECIFICATIONS

## 8875 RECEIVER

Operating Frequency: 82.315 kHz(RF), 815Hz(AF). 50/60~(PASSIVE)

Antenna mode: Null-responding vertical coil  
Peak-responding horizontal coil

Audio Indication Variable Pitch response on all frequencies.

Current Measurement Display indicated relative current simultaneously between any two selected cables for target cable verification in a multi-conductor environment.

Operating temp.: -4°F to 133°F(-20°C to +55°C)

Battery type Six 1.5V C-size Duracell alkaline

Battery life

Continuous 40 Hrs

Intermittent 82 Hrs (Auto power shutoff after 10 minutes of non-use)

Dimensions: 30.3"long x 3.75"wide x 9.4"high

Weight: 3 lbs

Signal Strength Analog LCD Bargraph. Absolute Digital Signal Strength readout from 0-999.

Gain Control Up/Down button for Automatic centering & manual control.

Dynamic Range 126 dB

### Depth Measurement

Automatic Push-button 3 digit readout to 15 ft. in feet-inches, (optional meter-centimeters).

#### \*Accuracy

815 Hz  $\pm(1-6)\%$  under normal conditions  $\leq$  ft.

82.315 kHz  $\pm(5-12)\%$  under normal conditions  $\leq$  ft.

Manual Bubble-level triangulation for verification of automatic readout in congested environments.

\*Depending on site conditions, non-concentric conductor shape, number of nearby conductors, and soil return currents.

# 8870 TRANSMITTER

Operating Frequency: 82.315 kHz(RF), 815 Hz(AF), and BOTH Simultaneous

Indicators AC Load Resistance Measurement, Low Bat Indicator, Low Bat warning modulated on output signal every 20 seconds.

Load Matching Automatic from 5Ω to 2000Ω

Output Power:	Normal	High
815 Hz(AF)	0.6 W	2.0 W
82.315 kHz(RF)	0.2 W	1.0 W
BOTH	0.12 W(AF)+.06 W(RF)	1.33 W(AF)+0.67 W(RF)

## Battery type options

Disposable Eight 1.5V Duracell D-size alkaline

Rechargeable 12V, 7 Amp-Hr maintenance-free sealed lead-acid includes 120VAC wall-mount charger for overnight recharging. Optional 12V automotive power pack for fast-charging, or powering unit from a Cigarette Lighter Jack.

## Battery life:

Disposable

Continuous 8-15 Hrs depending on load, frequency & power setting

Intermittent 40-60 Hrs depending on load, frequency & power setting. 25% duty cycle average

Rechargeable

Continuous 10-20 Hrs depending on load, frequency & power setting.

Intermittent 50-70 Hrs depending on load, frequency & power setting. 25% duty cycle average.

Operating temp.: -4°F to +133°F(-20°C to +55°C).

Dimensions: 16"long x 6.32"wide x (5-6)" high.

Weight: 8 lbs. with alkaline D-Cells, 11.5 lbs. with Rechargeable.

# 8875 RECEIVER

## **FACTORY SERVICE**

The Rycom Model 8875 was designed for dependable operation without periodic adjustment and calibration. If, however, your 8875 is not working properly, return it to the factory for repair. Send it prepaid to:

Rycom Instruments, Inc.  
9351 E. 59th Street  
Raytown, MO 64133 U.S.A.  
Telephone: 816-353-2100  
or 800-851-7347

We will repair and ship the instrument back within 10 working days, or advise you if the instrument is unrepairable.

Note: There is a minimum charge for repair and handling.

When shipping your instrument, be sure to include:

1. The name, address, and phone number of your contact.
2. A brief description of the trouble.
3. The return shipping address and department mail address, along with any special shipping instructions.

Packing Instructions:

Remove and discard all batteries. Place the unit to be repaired in the original shipping carton, or equivalent sturdy container. Add packing material around all sides of the unit. Seal the shipping container with strong tape. Mark the shipping container:

## **FRAGILE ELECTRONIC EQUIPMENT**

## WARRANTY

This instrument is under warranty for one year from date of delivery against defects in material and workmanship (EXCEPTION -- BATTERY). We will repair or replace products that prove to be defective during the warranty period.

This warranty is void if, after having received the instrument in good condition, it is subjected to abuse, unauthorized alteration or casual repair.

NO OTHER WARRANTY IS EXPRESS OR IMPLIED. THE WARRANTY DESCRIBED IN THIS PARAGRAPH SHALL BE **IN LIEU** OF ANY OTHER WARRANTY, INCLUDING BUT NOT LIMITED TO ANY IMPLIED WARRANTY OF **MERCHANTABILITY** OR FITNESS FOR A PARTICULAR PURPOSE. WE ARE NOT LIABLE FOR CONSEQUENTIAL DAMAGES.

## NOTES

# NOTES

9351 E. 59th Street  
Raytown, MO 64133  
Telephone: 816-353-2100  
or 800-851-7347  
FAX: 816-353-5050

Part Number 030 00052 00

PRINTED IN U.S.A.  
SUPPLEMENT PRINTED (950301)  
FIRST PRINTING (950501)